

Calibration Certificate

Calibration provided by : EKO Instruments Co., Ltd.
1-21-8, Hatagaya, Shibuya-ku, Tokyo, 151-0072, Japan

Manufacturer :	EKO Instruments Co., Ltd.	Issue Date :	August 27, 2018
Model :	MS-711	Calibration Date :	August 14, 2018
Description :	Spectroradiometer	Calibration Procedure :	110225-1.1
Serial Number :	S18007.10	Calibration method :	Lab calibration
Accessories :	Cable10m		
Certificate Number :	S18007.10-ES18-078		

Calibration uncertainty

Wavelength range	Combined uncertainty	Exposure time settings
300nm - 350nm	+/- 17.4 %	1000ms
350nm - 450nm	+/- 5.1 %	500ms
450nm - 1050nm	+/- 4.2 %	500ms
1050nm - 1100nm	+/- 5.3 %	1000ms
350nm - 1100nm (wavelength accuracy)	+/- 0.2nm	-

Calibration condition

Conditions	Unit	Note
Ambient temperature	25 °C	-
Orientation of lamp filament	Vertical	-
Orientation of spectroradiometer	90 degrees Tilted	-

Standard lamp

		Note
-	-	
Lamp type	OL-FEL-C Tungsten Halogen	1000W
Lamp S/N	F1509	-
Calibration date	2018/3/28	Max. 50 hours

I. Sunaga

I. Sunaga / Manager of Mfg. Dept.

T. Konuma

T. Konuma / Inspector

Certificate Number : S18007.10-ES18-078

Calibration procedure

The MS-spectroradiometer is calibrated against a NIST traceable tungsten-halogen OL-FEL standard lamp at a distance of 50 cm. The standard lamp has a known spectrum and the absolute irradiance is calibrated at several wavelengths. By measuring the spectroradiometer's detector responsivity in counts as a function of the irradiance at corresponding wavelengths, the sensitivity of each photo diode array pixel is converted into absolute units ($W/m^2/\mu m$).

The calibration function is determined by averaging 10 single measurements, measured separately for 4 different wavelength intervals each with a fixed exposure time. This is to use optimal output characteristics of the detector. Finally the calibration function is uploaded to the spectroradiometer firmware for automatic conversion of measured count into absolute units.

Calibration Uncertainty

The combined uncertainty of the calibration function for each wavelength interval is based on individual uncertainties contributed by the standard lamp, calibration set-up and spectroradiometer performance properties.

Source		Uncertainty			
		300 - 350nm	350 - 450nm	450 - 900nm	900 - 1100nm
Standard Lamp calibration	Gooch&Housego	2.74%	2.26%	1.91%	1.57%
Lamp current	Calibration set-up	0.12%	0.09%	0.04%	0.02%
Measurement repeatability	Spectroradiometer	6.00%	1.00%	1.00%	2.00%
Non-Linearity	Spectroradiometer	1.00%	1.00%	1.00%	1.00%
Alignment	Calibration set-up	1.00%	1.00%	1.00%	1.00%
Temperature dependency	Spectroradiometer	0.25%	0.25%	0.25%	0.25%
Cosine response	Spectroradiometer	0.00%	0.00%	0.00%	0.00%
Stray Light	Spectroradiometer	6.00%	1.50%	0.60%	0.60%

$$\text{Uncertainty} = \left\{ \left(\text{Standard Lamp calibration}/2 \right)^2 + \left(\text{Lamp current}/2 \right)^2 + \left(\text{Measurement repeatability} \right)^2 + \left(\text{Non - Linearity} \right)^2 + \left(\text{Alignment} \right)^2 + \left(\text{Temperature dependency} \right)^2 + \left(\text{Cosine response} \right)^2 + \left(\text{Stray Light} \right)^2 \right\} / \sqrt{2} * 2$$

Traceability to NIST Standard

OL-FEL lamps are calibrated by direct comparison to a Gooch & Housego NIST traceable FEL 1000-Watt lamp. Gooch & Housego NIST traceable lamps are used for a maximum period of 50 hours (will be replaced afterwards).

Test Report of Cosine Response

Calibration provided by : **EKO Instruments Co., Ltd.**
1-21-8, Hatagaya, Shibuya-ku, Tokyo, 151-0072, Japan

Manufacturer : **EKO Instruments Co., Ltd.**
Model : **MS-711**
Description : **Spectroradiometer**
Serial Number : **S18007.10**
Certificate Number : **S18007.10-ES18-078**

Issue Date : **August 27, 2018**
Measurement Date : **August 02, 2018**
Measurement Procedure : **110225-1.1**

Cosine response

Zenith angle [°]	South side Error [%]	North side Error [%]	East side Error [%]	West side Error [%]
0	0.00	0.00	0.00	0.00
10	-0.02	0.25	0.39	0.07
20	-0.43	0.05	0.22	-0.32
30	-1.11	-0.23	-0.29	-0.73
40	-1.73	-0.88	-0.41	-1.14
50	-2.48	-1.03	-0.88	-1.80
60	-3.35	-1.64	-1.25	-2.14
70	-1.84	-0.03	0.37	-0.88
80	2.77	3.97	4.96	4.01

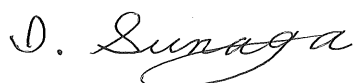

I. Sunaga / Manager of Mfg. Dept.



T. Konuma / Inspector

Cosine Response Measurement procedure

The cosine response of the Spectroradiometer is measured on an optical bench with a solar simulator as source. The solar simulator (AAA grade) is well adjusted with light parallelism, irradiance non-uniformity, and temporal stability. The zenith response is measured in angles of 10 degrees in 4 azimuth orientations (east, west, south, and north) and listed as the discrepancy relative to the ideal cosine response.

$$\text{Cosine Response} = \left\{ \left(\text{Output}_{\theta} / \text{Output}_{0\text{degree}} \right) / \text{Cos}(\theta) - 1 \right\} \times 100$$

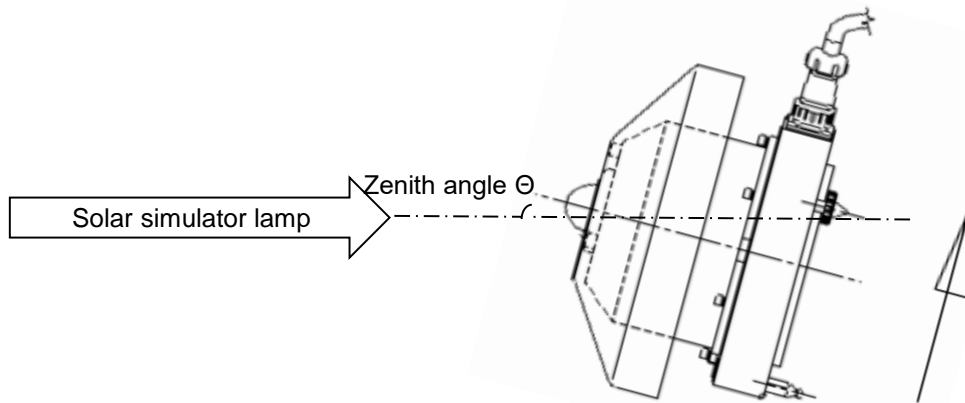

Figure 1. Configuration when measuring the South Direction

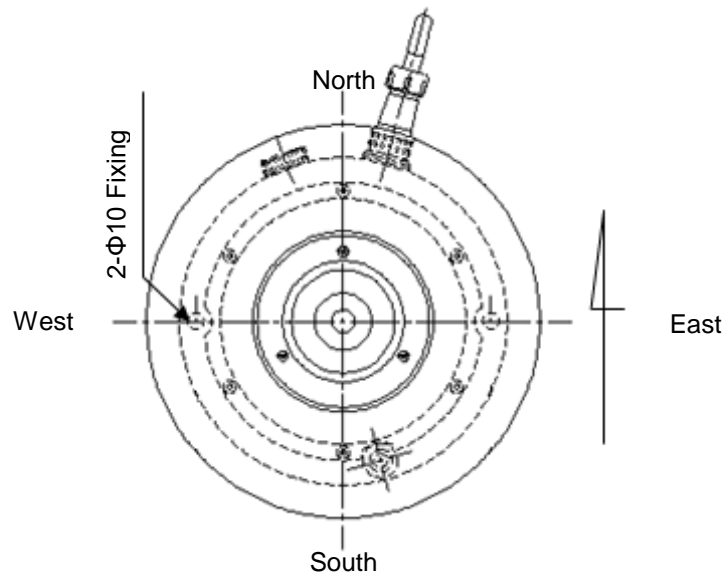

Figure 2. Direction of the Spectroradiometer (Image from top)